

金型結露防止装置

温度範囲: 10~40°C
送風量: 10~25m³/min

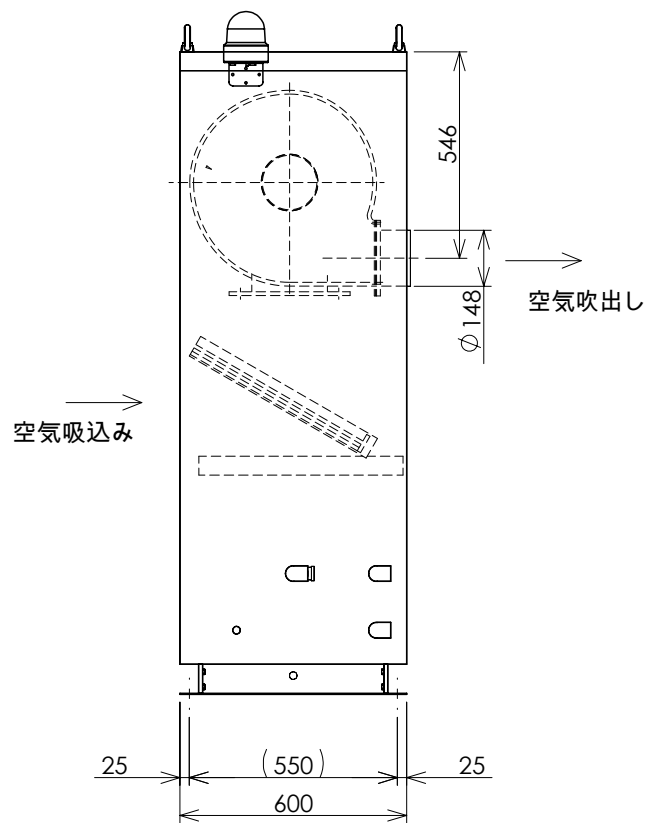
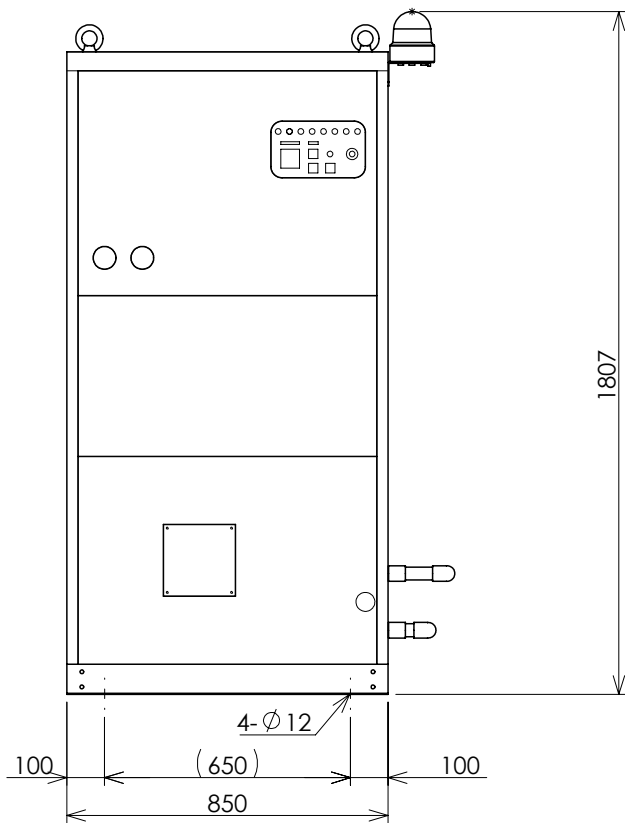
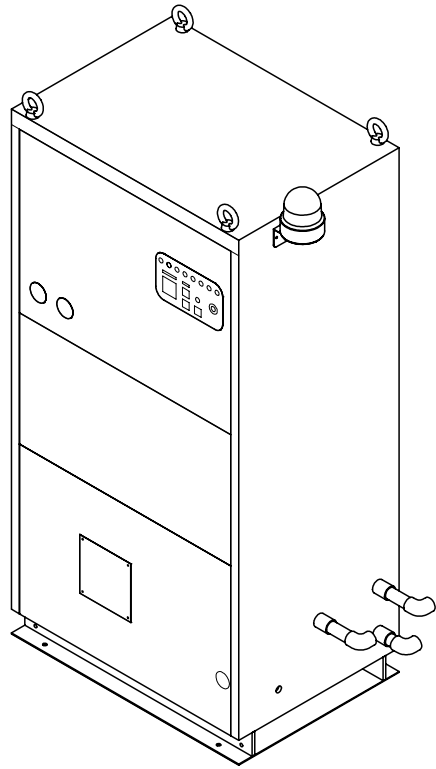
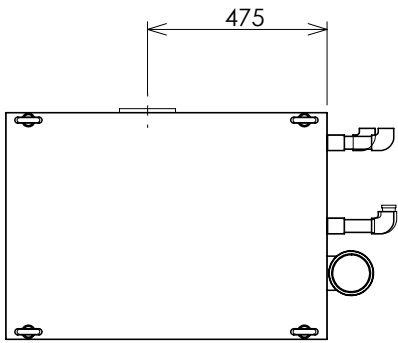

金型結露防止装置

強制排水装置

排出ポンプ: 3.0m³/h at 44m

